

Drawing Detail		Construction	
Wire Number	W017	All Materials RoHS Compliant	
Revision	R1A	Length	301.5mm
Engineer	ME	Gauge	22 AWG
Approval	SM 2021-04-26	Connector	M3511
Date Created	2021-02-03	Crimp	N/A
Date Modified	2021-07-15	Jacket Color	RED
Changes	STRIPPED LENGTH	Jacket Material	PU
Tolerance per mm	Length > 30mm: ± .04 mm	Insulator Colors	RED & BLACK
	Length < 30mm: ±.15 mm	Insulator Material	PVC
	Diameter: ± .03 mm	Scale: 1:1	Sheet: 2/3

This document contains proprietary information and may not be copied or shared without the consent of Voltaic Systems

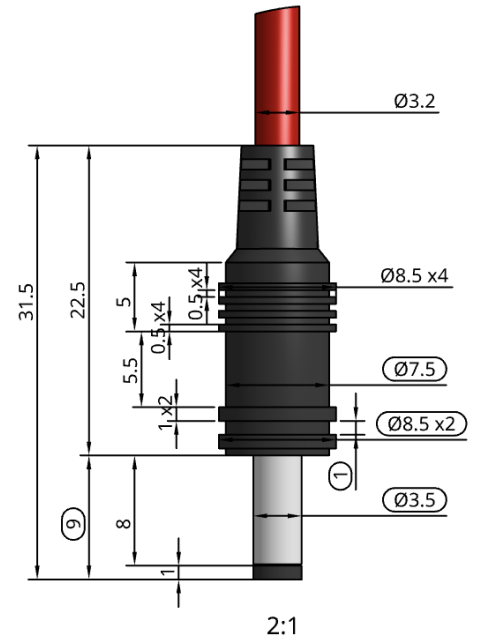

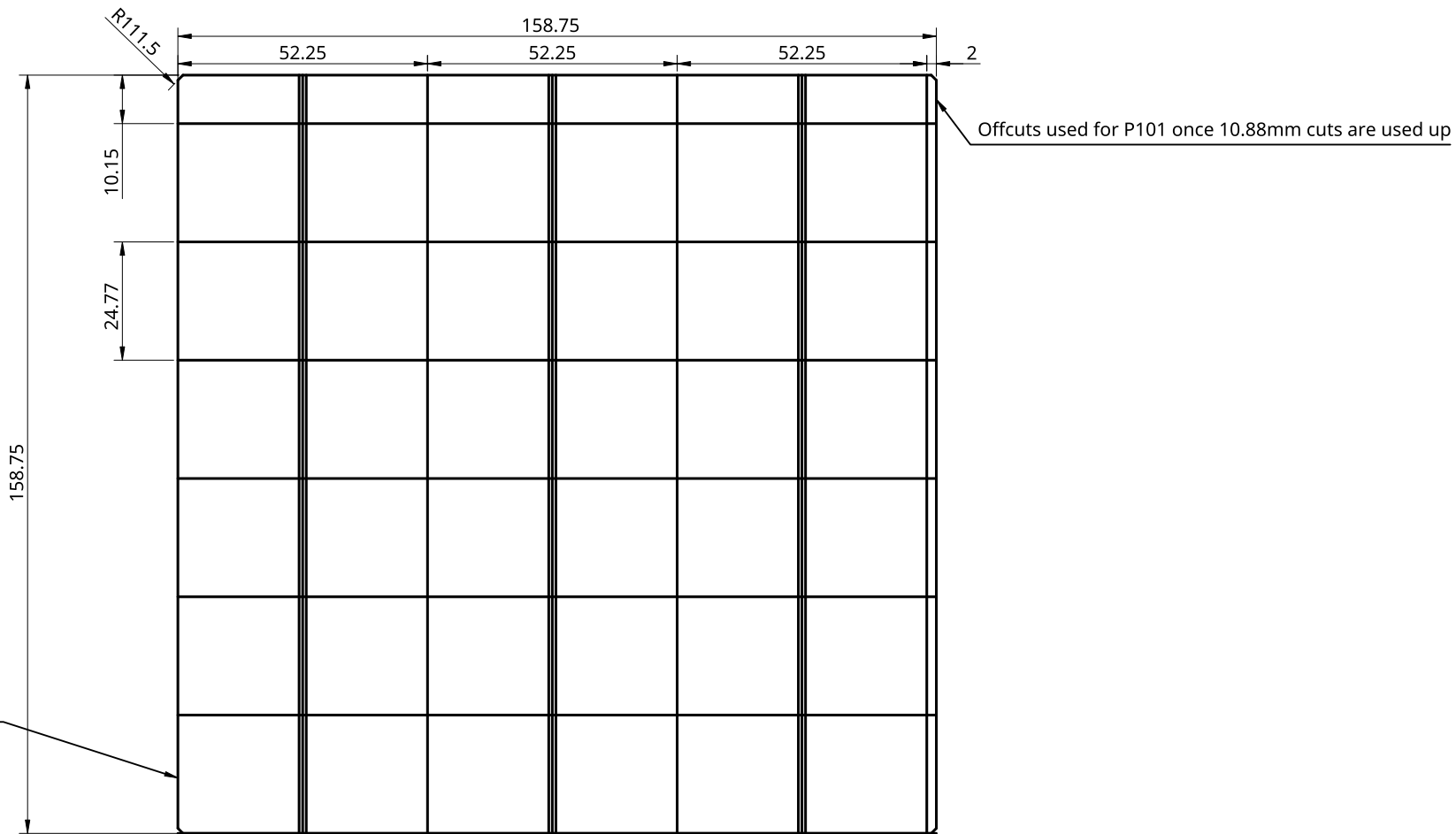

Cell Cut Diagram

Cell	EEPV EE6F3B 3BB G1-V
Cell Efficiency	>20.7%
Panel Reference	P107
Panel Revision	R5F
Date Created	2021-02-03
Date Modified	2021-07-15
Approval	SM 2021-04-27
Tolerance: ± 0.3 mm	Units: mm
Scale: 1:1.4	Sheet: 3/3

This document contains proprietary information and may not be copied or shared without the consent of Voltaic Systems